

# Energy efficient routing of MANETS using modified DEL-CMAC protocol

Nandhini. J

Assistant professor, Department of Electronics and Communication Engineering

Nandini. S, Nivetha . S, Selvapriya. R.N,

UG Scholars, Department of Electronics and Communication Engineering

Jay shriram group of institutions

***Abstract-MANET is a self configured network of multiple number of mobile nodes. Co-operative communication establishes the communication between source and destination through relay nodes. All the MANET operation planned with the considerations of the energy and bandwidth limitations. Co-operative communication utilizes nearby terminals to relay the overhearing information to achieve the diversity gains and improve the transmitting efficiency in the wireless networks. Some protocols CMAC, DEL-CMAC are used to reduce the complication of medium access interactions interms of co-operations. In this, a modified DEL-CMAC namely (distributed energy adaptive location based CMAC protocol based on IEEE 802.11 Distributed Co-ordination Function (DCF) which is a widely used standard for Ad-hoc communication. Modified DEL-Coop MAC increases the throughput , network efficiency and follows a best relay selection strategy by using cross layer scheme.***

***Index Terms-distributed adaptive location based cooperative medium access control, best relay selection.***

## I INTRODUCTION

Mobile ad-hoc network (MANET) is a collection of two or more devices or nodes or terminals with wireless communication and networking capability and communicate with each other without the aid of any centralized administrator also the wireless nodes that can dynamically form a network to exchange information without using any existing fixed network infrastructure. Some of the mobile terminals of the MANET are cell phones, portable gaming devices, tablets, PDA (personal digital assistance). This terminal may reach the internet even there is no coverage of Wi-Fi access point and the cellular base station. MANET's are also used in rescue and recovery process. Some of the issues in the mobile ad-hoc network are battery power, energy resource and network lifetime.

In existing CMAC protocol, it fails to investigate the energy efficiency or network lifetime but it mainly focus on throughput enhancement meanwhile the works on network

lifetime and energy efficiency usually attach on physical or network layer. Our work based on MAC layer and distinguished from previous protocols. By considering an energy consumption on both transceiver and transmit amplifier (practical energy model) with the aim to improve network lifetime and to enhance energy efficiency. In the proposed protocol, the tradeoff between gains by cooperation and extra overhead.

The overall network performance will significantly affected by interference ranges alteration in both space and time. In addition, we mention the issue of effective co-ordination over multiple concurrent co-operative function with varying transmitting power. In this paper, we propose modified DEL-CMAC protocol (modified distributed energy adaptive location based CMAC protocol) for MANET's. IEEE 802.11 distributed co-ordination function is used to design DEL-CMAC and it is a standard protocol for most of the wireless network.

DEL-CMAC consists of cross layer power allocation scheme, relay involved hand shaking process, innovative Network Allocation Vector (NAV) setting, a distributed utility based best relay selection strategy according to perspective of info theory, increasing the number of relay terminals the higher diversity gain can be achieved. Considering the MAC layer more relays leads to enlarged interference range and additional control frame overheads.

We have used NAV setting (network allocation vector) which is used for collision avoidance and enhance spatial reuse along with relay terminals and dynamic transmitting power. A cross layer optimal transmitting power allocation scheme is designed for desired outage probability requirement and also while maintaining throughput level the energy was conserved. A distributed energy-aware location based best relay selection strategy is merged compared to the existing schemes which is the important one for the MANET's.

Moreover, in a military environment, preservation of security, latency, reliability, intentional jamming, and recovery from failure are significant concerns. Military networks are designed to maintain a low probability of intercept and/or a low probability of detection. Hence, nodes prefer to radiate as little power as necessary and transmit as infrequently as possible, thus

decreasing the probability of detection or interception. A lapse in any of these requirements may degrade the performance and dependability of the network.

An ad-hoc network is a collection of wireless mobile hosts forming a temporary network without the aid of any stand-alone infrastructure or centralized administration. Mobile Ad-hoc networks are self-organizing and self reconfiguring multi hop wireless networks where, the structure of the network changes dynamically. This is mainly due to the mobility of the nodes. Nodes in these networks utilize the same random access wireless channel, cooperating in a friendly manner to engaging themselves in multi hop forwarding. The nodes in the network not only act as hosts but also as routers that route data to/from other nodes in network.

## II PERFORMANCE EXPLORATORY

In this system we state the energy preliminaries and the basic knowledge about DCF and DSR protocol.

### II.A DISTRIBUTED COORDINATION FUNCTION

Distributed coordination function is fundamental MAC technique of IEEE 802.11 based WLAN standard. Each station with a packet to transmit first senses the channel status whether it is busy or not. If the channel is sensed to be idle for an interval greater than the distributed inter-frame space (DIFS), the station proceeds with its further transmission. If the channel is sensed as busy, the station defers transmission till the end of the ongoing transmission. The station then initializes its back off timer with a randomly selected back off interval and decrements this timer every time it senses the channel to be idle. The timer is stopped when the channel is busy and the decrementing is restarted when the channel becomes idle for a DIFS again. The station starts its transmission when back off timer reaches zero. DCF also has an optional virtual carrier sense mechanism that exchange short (RTS) request to send and clear to send (CTS) frames between source and destination station during data frame transmission.

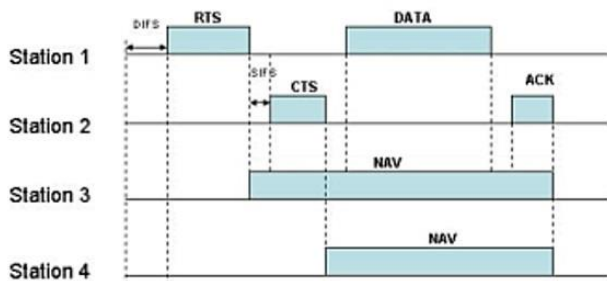

FIG 1.0 DISTRIBUTED COORDINATION FUNCTION

### II.B DSR(DYNAMIC SOURCE ROUTING)

The Dynamic Source Routing protocol is simple and efficient routing protocol designed specifically for use in multi-hop wireless ad-hoc network of mobile nodes. DSR allows the network to be completely self-configuring without need for any existing network infrastructure. The use of source routing allows the packet routing to be trivially loop-free avoids the need for up-to-date routing information in the intermediate nodes through which packets are forwarded, and allows nodes forwarding overhearing packets to cache the routing information in them for their own future use.

There are two mechanism in DSR protocol namely route discovery and route maintenance. In route discovery, when some node originates a new packet destined to some other node, it places in header of the packet a source route giving the sequence of hops that the packet should follow on its way. Normally, when the originated node will obtain a suitable source route by searching its route cache of router previously learned but if no route is found in its cache, it will initiate the route discovery protocol to dynamically find a new route. In route maintenance, when originating or forwarding a packet using a source route each node transmitting the packet is responsible for confirming that packet has been received by next hop along the source route, the packet is retransmitted until this confirmation is received.

The advantage of this DSR protocol is used a reactive approach which eliminates the need to periodically flood the network with table update message which are in table driven approach. The intermediate nodes also utilize the efficiently to reduce control overhead.

The disadvantage of this DSR protocol is the route maintenance mechanism does not locally repair a broken link. The route cache information could also result in inconsistencies during the route reconstruction phase.

### II.CCMAC (COOPERATIVE MAC)

Relay terminals cooperating for data transmission by means of CCMAC which is based upon wireless distributed coordination function. When the source station has a new MAC protocol data to send it can either transmit directly to the destination or use an intermediate helper for relaying. Beyond its normal function a request to send (RTS) message is used by coop MAC to notify the station that has been selected for cooperation moreover coop MAC introduce a new message called HTS, helper ready to send, which is used by the helper to indicates its availability after it receives the RTS message from the source. If the destination hears the HTS message, it issues a clear to send message CTS to reserve the channel time for two hop transmission. Otherwise, it still sends out the CTS, but only reserves the channel for a direct transmission. If both HTS and CTS are received at the source, the data packet should be transmitted to the helper first and then forwarded to the

destination by helper. If the source does not receive HTS, it should then initiate a direct transmission to the destination. A normal ACK is used to acknowledge a correct reception regardless of whether the packet is forwarded by the helper or is directly transmitted from the source. If necessary, re-transmission is attempted again in cooperative fashion. While forwarding, it is based on the demand of the acknowledgement for the particular packet from the receiver or destination to the sender or the transmitter.

II. DAODV (AD-HOC ON-DEMAND DISTANCE VECTOR)

Ad-hoc On-demand Distance Vector (AODV) is a reactive routing protocol, in which routes are determined only when needed. In AODV route discovery, it uses hop-by-hop routing and each node forwards the request only once. And then the reverse paths are formed when a node hears a route request. Route reply is forwarded through the reverse path while the forward path is used to route data packets. In route expiry, unused paths are expired based on a timer.

The main advantage of this AODV protocol is that routes are established on demand and destination sequence numbers are used to find the latest route to destination. The connection setup delay is less. The one disadvantage is that intermediate nodes can lead to inconsistent routes if the source sequence number is very old and intermediate nodes have a higher but not latest destination sequence number, thereby having state entries. Also multiple route request packets to a single route packet can lead to heavy control overhead.

The major difference between AODV and DSR stems out from the fact that DSR uses source routing in which a data packet carries the complete path to be traversed. However in AODV, the source node and intermediate nodes store the next-hop information corresponding to each flow for data packet transmission.

II. EDECODE AND FORWARD

DEL-CMAC uses decode and forward protocol with maximum ratio combiner in the physical layer. The process can be divided into two phases. The source senses the data to destination due to the broadcast nature of wireless medium the relay can overhear the signal which happens in first phase. The signal received at the destination and relay.

The transmitting power at the source and the transmitting data with the unit power is given. The distance of the source destination and source relay,  $h$  is the channel gain between two terminals and  $n$  is the additive noise. In the second phase the relay can decode the signal it re-transmits the data to the destination; otherwise it keeps silence the signal from the

relay to the destination in the second phase. Where,  $I$  is equal to 1 or 0, depending on whether the relay can decode the message correctly or not. In the analog domain the destination coherently combines transmitted from the source in the first phase and transmitted from the relay in the second phase by maximum ratio combiner.

Comparing with direct transmission, CC with maximum ratio combiner reduces the receiving threshold which benefits at two folds. (i) The transmission range is extended while the transmitting power is kept constant (ii) The transmitting power is decreased while serving the transmission range.

III ANALYSIS ON MODIFIED DEL-CMAC

DEL-CMAC is similar to wireless DCF protocol, the RTS/CTS handshake is used to reserve the channel at first. In the case of small transmitting power the cooperative transmission is not necessary, because the additional overhead for coordinating the relaying overtakes the energy saving from diversity gain. By introducing a transmitting power for direct transmission, those inefficient cases are avoided. The frame transferring process of DEL-CMAC is shown in Fig 2.

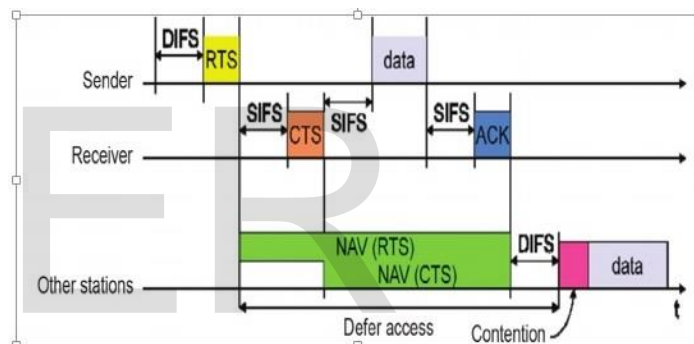

Fig 2.0 FRAME TRANSFERRING PROCESS IN DEL-CMAC

III A OPERATION AT THE SOURCE

At first, source generates the channel to check if it is idle, then it wants to initiate the data transmission with payload length  $L$  bytes. The source chooses a random back off timer between 0 and  $CW$ , if the channel is idle for DIFS. The source sends out a RTS, when the back off counter reaches zero. Monitor that different from DCF the location details of the source is carried in the RTS, that is used in the optimal power allocation mechanism.

If the source fails to receive a CTS within  $T(RTS)+T(CTS)+SIFS$ , then the re-transmission starts. In the case that FLAG P of CTS is 0, the DEL-CMAC is reduced to DCF protocol and it emits its operations in the following. When the FLAG P is 1, the source waits for another,  $T_{max}$  backoff +

$T_{ETH} + SIFS$ , where  $T_{max}$  backoff is the maximum backoff time for relay.

When the really capability is reduced ETH is not received. The source sends the data by direct transmission with data rate R.

After waiting for TII+SIFS both CTS and ETH are received, the source starts a co-operative transmission with the data rate 2R using the optimal transmitting power pcpiggybacked in the ETH. We consider that the terminal can support two transmission rate by different coding and modulation schemes.

The source would perform a random backoff same as DCF, if an ACK is not received after  $16(L+L_h)/2R + TACK + 2SIFS$ , where  $L_h$  is the header length (in bytes). on the other hand, the transmission process achieves and the source deal the next packet in the buffer. Identify that the unit for the data rate is bits per second and the unit for L and  $L_h$  is byte, so that the transmission time for one data frame is  $8(L+L_h)/2R$ .

### III.B OPERATION AT RECEIVER

On receiving the RTS, the destination sends SIFS and also CTS. The CTS consists the location information of the destination, the FLAG P, and the transmitting power for the direct transmission  $P_s^D$  (4 bytes), it is used for the available relay contention.

In the case that FLAG P is 1, if the destination has not found any ETH within, it consider that the direct transmission will be performed and waits for the data packet from the source.

Otherwise, the destination waits for the data packets from the source and achieving relay. If the destination can decode the combined signals correctly, it sends back an ACK. Unless, it just lets the source timeout and re-transmit.

### III.C OPERATION AT RELAY

If anyone terminal that receives both RTS and CTS (with FLAG P equals 1) and does not interface with other transmissions in its locality can be considered as a relay candidate. When receiving the CTS each relay candidate checks whether it is able to reduce the total energy consumption by

$$2P_r^C + P' * T_{II} - (P + 3P') * T_{ETH} > 0$$

$$C - P_r^C - P' * \frac{(L + L_h)}{2R} - 2P_s^D - P_s$$

Where  $P_s$  source and  $P_c$  receiver are the transmitting power of cooperative transmission mode for source and relay.  $\{PD\}$  source are the transmitting power are the direct transmission mode for source and fixed transmitting power respectively. The

CC is used to save energy consumption in transmitting the data named Additional energy consumption on control overhead.

By using equation the CC is verifying by the relay weather it reduces the total energy consumption on both transmitting and receiving compared to direct transmission. Back off timer is started by every capable relay candidate after SIFS interval.

Initially, the backoff at a best relay exist earlier thus the best relay will send out an ETH initially. The lost relays forfeit contention when sensing the ETH. The ETH consists the optimal transmitting power  $P_c$

The achieving relay broadcast the II message using power  $P_c^s$ , after SIFS. The interference range of the relay is reconfirm by the II message it is used to enhance the spatial reuse. Then the achieving relay waits for the data packet from the source to arrive. On receiving the data packet the achieving relay forwards it to the destination with data rate 2R using transmitting power  $P_c^r$ .

## IV. SYSTEM DETAILS AND IMPLEMENTATION

In this, we described about the DEL-CMAC supplements such as best relay selection, optimal power allocation scheme and network allocation vector setting in the following sub-sections.

### IV.A BEST RELAY SELECTION STRATEGY

The performance of the CMAC protocol significantly affected by selecting the best relay distribution. The existing relay selection schemes that incorporated into the CMAC protocols, depend mainly on the at present channel condition is invariant during one transmit session. According to channel condition, the best selected relay terminal during the route construction or handshaking period, may not be the best relay terminal based on the instantaneous location instead of instantaneous channel condition may be more reasonable for MANETS. In this, a distributed energy-aware location-based best relay selection strategy which is incorporated into the control frame exchanging period in DEL-CMAC. The location information of individual wireless devices can be obtained through GPS or other localization algorithms.

The required location information of source and destination is carried by RTS and CTS Frames. Thus no additional communication overheads are involved. DEL-CMAC chooses the best relay based on a utility based back-off, which depends on the required transmitting power to meet certain outage probability (related to individual location) and the residual energy of individual terminals. It is carried out in a distributed, lightweight and energy-efficient fashion, in which the backoff of the relay that has the minimum backoff utility function  $r$  as  $BU_r$ .

Then the terminal with high residual energy and low transmitting power, has a short backoff time. The terminal whose backoff expires first will be selected as the winning relay.

The threshold restrict the maximum backoff time within an acceptable range. Since when the residual energy is very low, it will be extremely large, leading to a very long backoff time that we should prevent. Incorporate the collision free relay selection strategies into our utility-based backoff scheme is our future work.

Different from the existing best relay selection schemes, the proposed strategy utilizes the location information and takes the residual energy into considerations. Besides, it is completely distributed and every terminals makes decision independently. Using the proposed relay selection strategy, the energy consumption rate among the terminals can be balanced, and the total energy consumption can be reduced.

In this , there is no additional overheads are involved . The DEL-CMAC chooses the best relay based on utility based back off which is based on transmitting power.

#### IV. BOPTIMAL POWER ALLOCATION SCHEME

For increasing energy efficiency optimal power allocation is indispensable for a cross-layer CMAC protocol. In this, we address the power allocation CC and direct transmission under the given outage probability. For deriving the transmission power at source in the direct transmission mode, which is calculated by the destination after it receives the RTS. Then, the optimal transmitting power at source and relay in the cooperative transmission mode is calculated by individual relay candidates after the RTS/CTS handshake which is under the same outage probability and end-to-end data rate.

#### IV. C DIRECT TRANSMISSION

In order to meet a desired outage probability, the minimum transmitting power in the direct transmission mode is given as

$$p_s^D = \frac{2}{\ln(1 - p_D^o)} (|R - 1)N_0 d_{sd}^\alpha$$

where, R is the transmission rate, then distance between the source and the destination, path loss exponent, the channel fading gain and variance of noise component. Due to the space constraint, we provide the derivation.

#### IV. D COOPERATIVE TRANSMISSION

The optimal power allocation for cooperative transmission exists when the transmitting power at the source equals the transmitting power at the relay . Then the following equation given by

$$2$$

$$G(d) = \exp(2R - 1N_0 d)$$

—

#### IV. E SPATIAL REUSE ENHANCEMENT

As the involvement of relaying and varying transmitting power, the interference ranges in DEL-CMAC are changing during one transmit session. In order to avoid the interference and conserve the energy, delicate NAV setting is required. NAV limits the use of physical carrying sensing, thus conserves the energy consumption, The terminal listening on the wireless medium read the duration field in the MAC frame header, and set their NAV on how long they must differ from accessing the medium taking IEEE 802.11 DCF for instants, the NAV is set using RTS/CTS frames. No medium access is permitted during the blocked NAV duration.

Comparing with the simple NAV setting in DCF, the setting in DEL-CMAC needs to be considerably modified. The presents of relays, will enlarge the in reference range and the dynamic range makes the interference ranges varying during one transmit session. Unusual NAV setting includes energy waste and collisions. Then , setting the NAV during too short will wake up the terminals too soon, which results in energy based due to medium sensing. On the other hand, setting is too long will reduce the spatial efficiency, which results to the performance degradation in terms of throughput and delay. Thus, effective NAV setting is necessary and critical. Unfortunately, most of the previous works does not address the NAV setting issue in CC, not to mention the one with varying transmitting power. In this paper, we divide the transmission ranges for the source, destination and relay to 5 different regions. Since, different transmitting power lead to different transmission ranges, their exist two ranges for the delay. The solid circle denotes the transmission range for fixed transmitting power (with radius r1) and the dashed circle denotes the transmitting range with allocated transmitting power at the source, since all the terminals lie inside the solid circle of the source will interfere with the ACK. Thus, they must differ accessing the medium until the very end of the whole session. In the following, we address the specific NAV setting forever DEL-CMAC from the perspective of different regions.

#### IV. E. a REGION 1 (THE TERMINALS THAT CAN RECEIVE BOTH THE RTS AND CTS1)

The terminals in this region are the relay candidates. According to our DEL-CMAC, they contend for the winning relay after the RTS/CTS exchange. Upon receiving the ETH, all the lost relays should keep silence until the whole transmit session is finished. Notice, that for the sake of the relay

selection, the terminals can't set their NAVs as soon as they receive the RTS as in the IEEE 802.11 DCF. All the neighboring terminals have to wait until the end of CTS and then make their decisions. Thus, the NAV duration in region.

IV.E.b REGION 2

The terminal that can receive the RTS but not the CTS set their NAV duration till the end of the acknowledgement.

IV.E.c REGION 3

The terminals that can receive CTS but not the RTS. The operations of the terminals in the region 2 and 3 are the same in which they set their NAV setting till the end of the acknowledgement.

IV.E.d REGION 4

The terminals that can receive the interference indicator. As explain before based on the different transmitting power, there are two transmitting ranges at the relay. First one is the transmission range with fixed transmitting power for the ETH message, next is the transmission range and data with allocated transmitting power for the second message. The region 4 terminals fall inside the small transmission range at the relay, until the data transmission ends they should differ the medium access. Recall that in 802.11 DCF the NAV setting is not set by the nodes outside the transmission ranges of source and destination, to avoid the possible collision the physical carrier sensing is used. Thus as in 802.11 in DCF, the NAV duration for region nodes ends before the acknowledgement frame. The duration of NAV setting for them is  $16(L+L_h)/2R+2SIFS$ .

IV.E.e REGION 5

The terminals can receive the ETH in the absence of II. The terminals in this region fall inside the large transmission range but outside the small one. Some terminals have a short NAV duration comparing to region terminals which is only  $8(L+L_h)/2R$ . The terminals in the region 5 and the relay may not interfere with each other when the source completes its data transmission. The nodes in this region may initiate their transmission by utilizing the II frame in the advance there are outside the range of destination.

V PERFORMANCE ANALYSIS

To evaluate DEL-CMAC through extensive simulation comparing with IEEE 802.11 DCF and cooperative MAC. In this, the performance metrics are transmitting power, total energy consumption, network lifetime, throughput. Throughput is defined as the total number of bits transmitted per second. It is also defined as the total number of data that destination receives them from source divided by time, it takes for destination to get

final packet. If one are more nodes in MANET are destroyed then network will not work fairly. It will endure the aggregate system effectiveness. If the remaining energy of the node remains high then automatically lifetime of the system is extended.

V.A SINGLE HOP SCENARIOS

The single-hop ad hoc network networks were nodes do not act as a router and therefore communication is possible only between the nodes which are within each others. The proposed work is for enhancing network lifetime and energy efficiency. MAC protocol is used for improving the network life time in DEL-CMAC. This reduces the use of energy and system will be energy efficient, also the power required in the system is reduced. Then the best relay selection and power allocation strategy is used for selecting relay and for minimal power allocation to each node in a network. Each node can act as a host or router otherwise parent or a child.

V.B MULTI HOP SCENARIOS

The example for the performance of DELCMAC in a realistic multi-hop multi connection scenario along with IEEE 802.11 DCF and Coop MAC. This complex procedure takes the collision and interference that are caused by different connection into an account are randomly placed in a squared area of 200 x 200. All the terminals that belongs to the same sub-net are indicated by the dashed lines. The five CBR (Constant Bit Rate) connections, in which sources (nodes 1,11,21,31,41) transmit UDP based traffic at one packet per hundred milliseconds to the destination through multi hop network the length is set to 1024 bytes for the data payload.

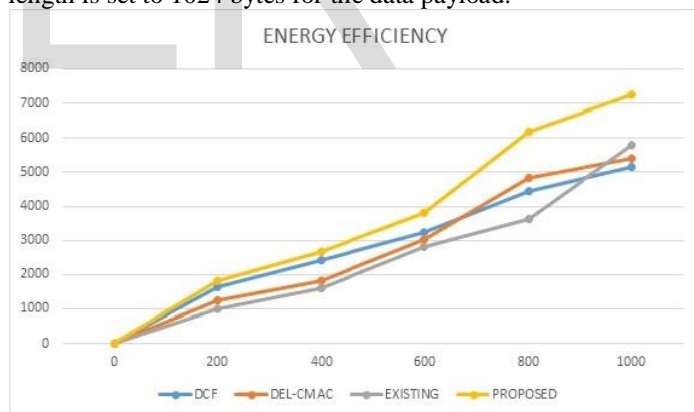

FIG 3.0 ENERGY EFFICIENCY

The routing paths which is widely used in MANETs is established by using the AODV routing protocol. Some other routing protocols like DSR or energy aware routing protocol can be used. The performance of the MAC layer schemes is independent of network layer schemes. On comparing the network lifetime of DEL-CMAC and IEEE 802.11 DCF, Coop

MAC in a static network it is clear that DEL-CMAC performance is good and it always outperforms DCF and Coop MAC in all cases.

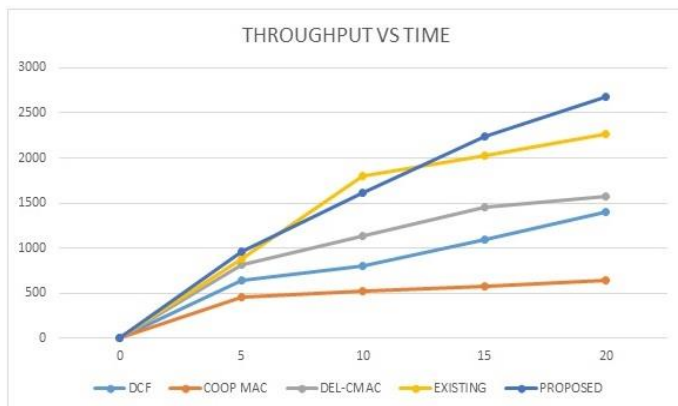

FIG 4.0 THROUGHPUT

Coop MAC is commonly used for increasing the throughput. The Coop MAC has the shortest network life time, due to the lacking of power control and the additional control overhead for cooperative communication network. By comparing DCF and Coop MAC the performance of DEL-CMAC

performance gain is high when increasing the number of terminals. The reason can be explained by the means of two aspects, first one is some terminals have to play source and cooperative relay when the node density is low. The balanced energy consumption is achieved as the result of growing availability of relay candidates. The node density of the node is high enough, the terminals having their own data to send or serving as routing relay, which are selected as the cooperative relay for other connections. Second, by increasing the node terminal the probability that the relay candidates are located in ideal positions for the existing source-destination pairs.

#### VI CONCLUSION

In this paper we have proposed a novel distributed energy adaptive location based co-operative MAC protocol for MANETS. Energy and location adaptive can be exploited by introducing DEL-CMAC. So that the network lifetime is increased rapidly. Also proposed an effective relay selection strategy which is used to choose the best relay terminal. To set the transmitting power, the cross layer optimal power allocation scheme is used and also enhanced the spatial reuse to minimize the interference over different connection by using (NAV) Network Allocation Vector setting. When comparing to IEEE 802.11 DCF and co-operative MAC, DEL-CMAC increases the network lifetime effectively. As a further work, we will analyze the DEL-MAC for large scale network size and

with high mobility and also to develop an effective cross layer co-operative diversity-aware routing algorithm along with DEL-CMAC to consume energy mean while minimizing throughput and delay degradation .

#### REFERENCES

- [1] Xiaoya Wang ,jie Li ,“Improving the network lifetime of MANET’s through cooperative MAC protocol design”IEEE Transactions on Parallel & distributed systems Vol.No.2015
- [2] Bora Karaoglu and Wendi Heinzelman, “Cooperative Load Balancing and Dynamic Channel Allocation for Cluster-Based Mobile Ad-Hoc Networks” IEEE Transactions on Mobile Computing, Vol 14, No 5.2014.
- [3] L.Femila, V.Vijayarangan “Transmission power control in mobile Ad-Hoc using network coding and cooperative communication “IEEE transactions on network performance evolution, vol.no.2014
- [4] Imane M.A Famy ,Hesham.A,LailaNaseff “PEEBR: Predictive Energy Efficient Bee Routing algorithm for Ad-hoc wireless mobile networks”Vol.no.10.2012
- [5] Choonlingwee ,Yang Qin,Y.Y.,Wen”A routing protocol with energy and traffic balance awareness in wireless Ad-Hoc Networks”IEEE Transactions on load balancing Vol.no.9.2007
- [6] Swati A Patel,Dhaval Patel, “Dynamic Channel Allocation In Mobile Network”,ISSN, Vol 2,issue-8,2005.
- [7] WieLiu,Yangchao Zhang ,yuangFang“CONSERVE ENERGY THOROUGH MULTIPLE PACKET TRANSMISSION IN HETEROGENEOUS MOBILE Ad-Hoc network”ISSN 2005
- [8] E.AkilaDevi,K.Chithra”SECURITY BASED ENERGY EFFICIENT ROUTING PROTOCOL FOR Ad-Hoc Network”IEEE Transactions on network lifetime and performance 2014
- [9] Yi-Cheng Huang, Sheng-Yan Chuang and Sheng-De Wang” A Dynamic Node Degree Management scheme for ENERGY-EFFICIENT ROUTING PROTOCOLS in wireless mobile Ad-Hoc Network
- [10] R.Valikannu,A.George;s.k.Srivatsa”A Novel Energy Consumption Model Using Residual Energy Based Mobile Agent Selection Scheme (REMA)in MANET’s”IEEEjournal 2014
- [11] BhavnaSharma,shailachugh,vismajay”energyefficient load balancing approach to improve AOMDV Routing in manet”IEEE transactions 2014 vol.no.13
- [12] J.N Laneman,D.N.C.Tse,and G.W. Worenell,”cooperative diversity in wireless networks:efficient protocols and outage behaviour,”IEEE Trans.Inform Theory,vol.50,pp.3062-3080,dec 2004.
- [13] A.Sendonaris,E.Erkip,and B.Aazhang,”user cooperation diversity-part I:system description,”IEEE Trans.commun.,vol.51,no.11,pp. 1927-1938, Nov . 2003
- [14] J.N Laneman,D.N.C.Tse,and G.W. Worenell,”Distributed Space-time-coded protocols for exploiting cooperative diversity in wireless network,”IEEE Trans.inform.Theory,vol.49,pp.2415-2425,oct.2003.

[15] J.Wu, M. Cardei, F.Dai, and S.Yang, "Extended Dominated Set and Its Applications in Ad Hoc Networks Using Cooperative communications," *IEEE*

*Trans.Parallel and Distributed systems*, vol.17, no8, pp. 851-864, Aug. 2006

[16] Y.Zhu, M.Haung, S. Chen and Y. Wang, "Energy-Efficient Topology Control in Cooperative Ad-Hoc Networks," *IEEE Trans and Parallel and distributed Systems*, vol.99, no.Rapidposts, 2011

[17] S. Cui, A. J. Goldsmith, and A. Bahai, "Energy-Efficient of MIMO and cooperative MIMO in sensor networks," *IEEE journal on Selected Areas in communications*, vol.22, no. 6, pp. 1089-1098, Aug. 2004.

[18] P.Liu, Z.Tao, S. Narayanan, T. Korakis and S.S. Panwar, "Coop MAC: a cooperative MAC for wireless LANs," *IEEE J.selected areas in commu.*, vol. 25, pp. 340-354 feb. 2007

IJSER